

# AHD Type

## 加長型橫向銑頭

## Modular Angle Head-Longer

- 小型化設計、加長型下座，適用於深槽與深孔之內面加工。
- 自動刀庫換刀加工（僅錐度 50 橫銑頭可換刀），量化生產必備工具。

- The body is made of Ductile Cast Iron. High strength steel; stable machining.
- The AHC series is suitable for firm and fast face milling.
- Can be automatic tool changed (Taper 50 Angle Head only). Increases productivity.

內孔偏擺度	0.002 mm
材質	球狀石墨鑄鐵
轉速	最高 4000 RPM
扭力	最大 15 Nm
齒輪比	1 : 1
適用主軸	BT, SK(ISO), CAT
標準配件	開口扳手、ER 扳手、ER 螺帽
出力軸轉向	反轉

Run-out	0.002 mm
Material	Ductile Cast Iron
R.P.M.	Max. 4000 RPM
Torque	Max. 15 Nm
Gear Ratio	1 : 1
Spindle Type	BT, SK(ISO), CAT
Standard Accessory	Open Wrench, ER Wrench, ER Nut
Output Rotation	Reverse to Input Rotation

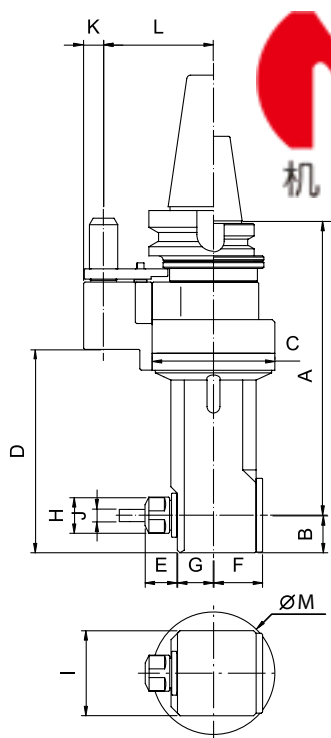

**思誠資源**  
WWW.SCZY.COM  
機床附件提供商



Unit : mm

Model No.	A	B	C	D	E max	F	G	H	I	J	K	L	M	N.W. (KG)
AHD-BT40-A1	227	29	95	156	38	38	28	34	66	1~13(ER20)	15.5	65/80/85	116	8.4
AHD-BT50-A1	238	29	95	156	38	38	28	34	66	1~13(ER20)	15.5	80/85/110	116	11
AHD-SK40-A1	227	29	95	156	38	38	28	34	66	1~13(ER20)	15.5	65/80/85	116	8.1
AHD-SK50-A1	238	29	95	156	38	38	28	34	66	1~13(ER20)	15.5	80/85/110	116	10.8
AHD-CAT40-A1	227	29	95	156	38	38	28	34	66	1~13(ER20)	15.5	65/80/85	116	8.1
AHD-CAT50-A1	238	29	95	156	38	38	28	34	66	1~13(ER20)	15.5	80/85/110	116	10.8
AHD-BT40-A3	227	29	95	156	47	38	28	42	66	2~16(ER25)	15.5	65/80/85	125	8.4
AHD-BT50-A3	238	29	95	156	47	38	28	42	66	2~16(ER25)	15.5	80/85/110	125	11
AHD-SK40-A3	227	29	95	156	47	38	28	42	66	2~16(ER25)	15.5	65/80/85	125	8.1
AHD-SK50-A3	238	29	95	156	47	38	28	42	66	2~16(ER25)	15.5	80/85/110	125	10.8
AHD-CAT40-A3	227	29	95	156	47	38	28	42	66	2~16(ER25)	15.5	65/80/85	125	8.1
AHD-CAT50-A3	238	29	95	156	47	38	28	42	66	2~16(ER25)	15.5	80/85/110	125	10.8

※ 此系列橫銑頭可選購延長器，以增加本體長度，詳細規格請見 P31。

※ For longer length, Extension is available, whose specification is shown on P31.